

TOSHIBA PHOTOCOUPLER GaAs IRED & PHOTO-TRANSISTOR

TLP627, TLP627-2, TLP627-4

PROGRAMMABLE CONTROLLERS
DC-OUTPUT MODULE
TELECOMMUNICATION

The TOSHIBA TLP627,-2 and -4 consists of a gallium arsenide infrared emitting diode optically coupled to a darlington connected phototransistor which has an integral base-emitter resistor to optimize switching speed and elevated temperature characteristics.

The TLP627-2 offers two isolated channels in a eight lead plastic DIP, while the TLP627-4 provide four isolated channels per package.

- Collector-Emitter Voltage : 300V(Min)
- Current Transfer Ratio : 1000%(Min)
- Isolation Voltage : 5000Vrms(Min)
- UL Recognized : UL1577,File No.E67349

	MADE IN JAPAN	MADE IN THAILAND
UL Recognized	E67349 *1	E152349 *1
BSI Approved	7426, 7427 *2	7426, 7427 *2

*1 UL1577

*2 BS EN60065 : 1994,BS EN60950: 1992

Unit in mm

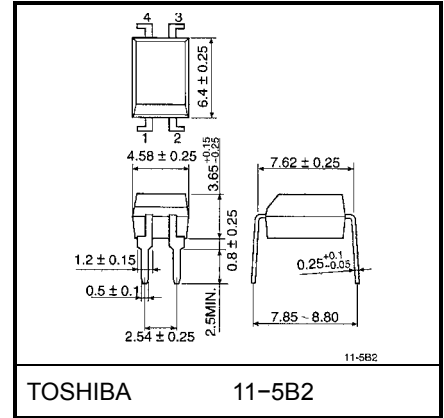

Weight: 0.26 g

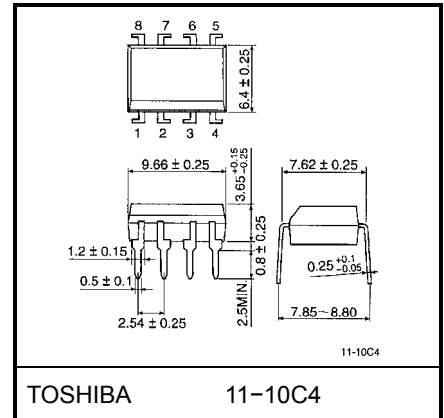

Weight: 0.54 g

PIN CONFIGURATION (TOP VIEW)

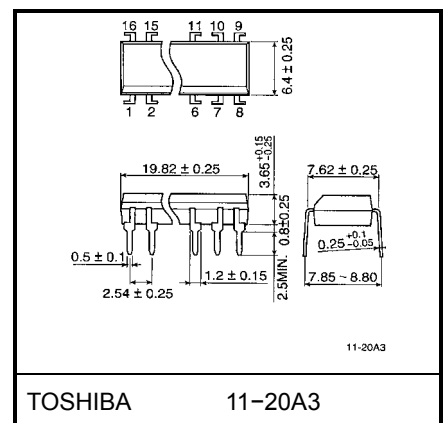
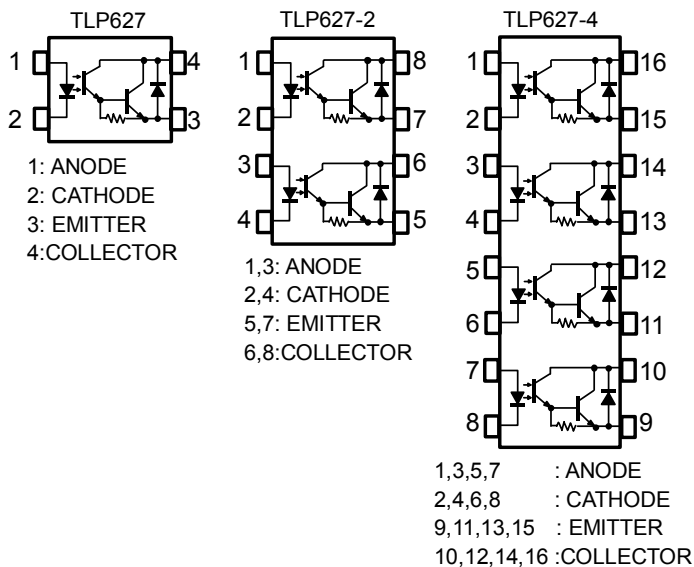

Weight: 1.1 g

MAXIMUM RATINGS(Ta=25°C)

CHARACTERISTIC		SYMBOL	RATING		UNIT
			TLP627	TLP627-2 TLP627-4	
LED	Forward Current	I_F	60	50	mA
	Forward Current Derating	$\Delta I_F / ^\circ\text{C}$	-0.7(Ta \geq 39°C)	-0.5(Ta \geq 25°C)	mA / °C
	Pulse Forward Current	I_{FP}	1(100 μ s pulse, 100pps)		A
	Power Dissipation (1 Circuit)	P_D	100	70	mW
	Power Dissipation Derating (Ta \geq 25°C, 1 Circuit)	$\Delta P_D / ^\circ\text{C}$	-1.0	-0.7	mW / °C
	Reverse Voltage	V_R	5		V
	Junction Temperature	T_J	125		°C
DETECTOR	Collector-Emitter Voltage	V_{CEO}	300		V
	Emitter -Collector Voltage	V_{ECO}	0.3		V
	Collector Current	I_C	150		mA
	Collector Power Dissipation (1 Circuit)	P_C	150(*300)	100	mW
	Collector Power Dissipation Derating (Ta \geq 25°C, 1 Circuit)	$\Delta P_C / ^\circ\text{C}$	-1.5(*-3.5)	-1.0	mW / °C
	Junction Temperature	T_j	125		°C
	Operating Temperature Range	T_{opr}	-55~100		°C
Storage Temperature Range	T_{stg}	-55~125		°C	
Lead Soldering Temperature (10s)	T_{sold}	260(10sec)		°C	
Total Package Power Dissipation	P_T	250(*320)	150	mW	
Total Package Power Dissipation Derating (Ta \geq 25°C, 1 Circuit)	$\Delta P_T / ^\circ\text{C}$	-2.5(*-3.2)	-1.5	mW / °C	
Isolation Voltage (AC, 1min. , R.H. \leq 60%) (Note1)	BV_S	5000		V _{rms}	

*IF=20mA Max

(Note1) Device considered a two terminal device : LED side pins Shorted together and DETECTOR side pins shorted together.

RECOMMENDED OPERATING CONDITIONS

CHARACTERISTIC	SYMBOL	MIN.	TYP.	MAX.	UNIT
Supply Voltage	V_{CC}	—	—	200	V
Forward Current	I_F	—	16	25	mA
Collector Current	I_C	—	—	120	mA
Operating Temperature	T_{opr}	-25	—	85	°C

INDIVIDUAL ELECTRICAL CHARACTERISTICS (Ta=25°C)

CHARACTERISTIC		SYMBOL	TEST CONDITION	MIN.	TYP.	MAX.	UNIT
LED	Forward Voltage	V_F	$I_F = 10 \text{ mA}$	1.0	1.15	1.3	V
	Reverse Current	I_R	$V_R = 5 \text{ V}$	—	—	10	μA
	Capacitance	C_T	$V = 0, f = 1\text{MHz}$	—	30	—	pF
DETECTOR	Collector-Emitter Breakdown Voltage	$V_{(BR)CEO}$	$I_C = 0.1\text{mA}$	300	—	—	V
	Emitter-Collector Breakdown Voltage	$V_{(BR)ECO}$	$I_E = 0.1\text{mA}$	0.3	—	—	V
	Collector Dark Current	I_{CEO}	$V_{CE} = 200\text{V}$	—	10	200	nA
			$V_{CE} = 200\text{V}, T_a = 85^\circ\text{C}$	—	—	20	μA
Capacitance Collector to Emitter	C_{CE}	$V = 0, f = 1\text{MHz}$	—	10	—	pF	

COUPLED ELECTRICAL CHARACTERISTICS (Ta=25°C)

CHARACTERISTIC	SYMBOL	TEST CONDITION	MIN.	TYP.	MAX.	UNIT
Current Transfer Ratio	I_C/I_F	$I_F = 1\text{mA}, V_{CE} = 1\text{V}$	1000	4000	—	%
Saturated CTR	$I_C/I_F(\text{sat})$	$I_F = 10\text{mA}, V_{CE} = 1\text{V}$	500	—	—	%
Collector-Emitter Saturation Voltage	$V_{CE}(\text{sat})$	$I_C = 10\text{mA}, I_F = 1\text{mA}$	—	—	1.0	V
		$I_C = 100\text{mA}, I_F = 10\text{mA}$	0.3	—	1.2	

ISOLATION ELECTRICAL CHARACTERISTICS (Ta=25°C)

CHARACTERISTIC	SYMBOL	TEST CONDITION	MIN.	TYP.	MAX.	UNIT
Capacitance Input to Output	C_S	$V_S = 0, f = 1\text{MHz}$	—	0.8	—	pF
Isolation Resistance	R_S	$V_S = 500\text{V}, \text{R.H.} \leq 60\%$	5×10^{10}	10^{14}	—	Ω
Isolation Voltage	BVs	AC, 1minute	5000	—	—	Vrms
		AC, 1second, in oil	—	10000	—	
		DC, 1 minute, in oil	—	10000	—	Vdc

SWITCHING CHARACTERISTICS (Ta=25°C)

CHARACTERISTIC	SYMBOL	TEST CONDITION	MIN.	TYP.	MAX.	UNIT
Rise Time	t_r	$V_{CC}=10V$ $I_C=10mA$ $R_L=100\Omega$	—	40	—	μs
Fall Time	t_f		—	15	—	
Turn-on Time	t_{on}		—	50	—	
Turn-off Time	t_{off}		—	15	—	
Turn-on Time	t_{ON}	$R_L=180\Omega$ (Fig.1) $V_{CC}=10V, I_F=16mA$	—	5	—	
Storage Time	t_s		—	40	—	
Turn-off Time	t_{OFF}		—	80	—	

Fig.1 SWITCHING TIME TEST CIRCUIT

