

LOW POWER DUAL VOLTAGE COMPARATORS

- WIDE SINGLE SUPPLY VOLTAGE RANGE OR DUAL SUPPLIES +2V TO +36V OR $\pm 1V$ TO $\pm 18V$
- VERY LOW SUPPLY CURRENT (0.4mA) INDEPENDENT OF SUPPLY VOLTAGE (1 mW/comparator at +5V)
- LOW INPUT BIAS CURRENT : 25nA TYP
- LOW INPUT OFFSET CURRENT : $\pm 5nA$ TYP
- INPUT COMMON-MODE VOLTAGE RANGE INCLUDES GROUND
- LOW OUTPUT SATURATION VOLTAGE : 250mV TYP. ($I_o = 4mA$)
- DIFFERENTIAL INPUT VOLTAGE RANGE EQUAL TO THE SUPPLY VOLTAGE
- TTL, DTL, ECL, MOS, CMOS COMPATIBLE OUTPUTS

DESCRIPTION

This device consists of two independent low power voltage comparators designed specifically to operate from a single supply over a wide range of voltages. Operation from split power supplies is also possible.

These comparators also have a unique characteristic in the fact that the input common-mode voltage range includes ground even though operated from a single power supply voltage.

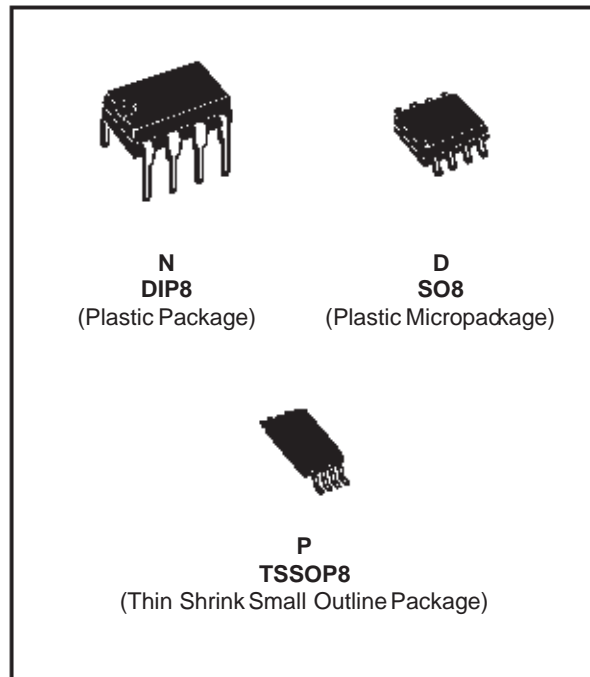

ORDER CODES

Part Number	Temperature Range	Package		
		N	D	P
LM2903	-40, +125°C	•	•	•
Example : LM2903N				

PIN CONNECTIONS (top view)

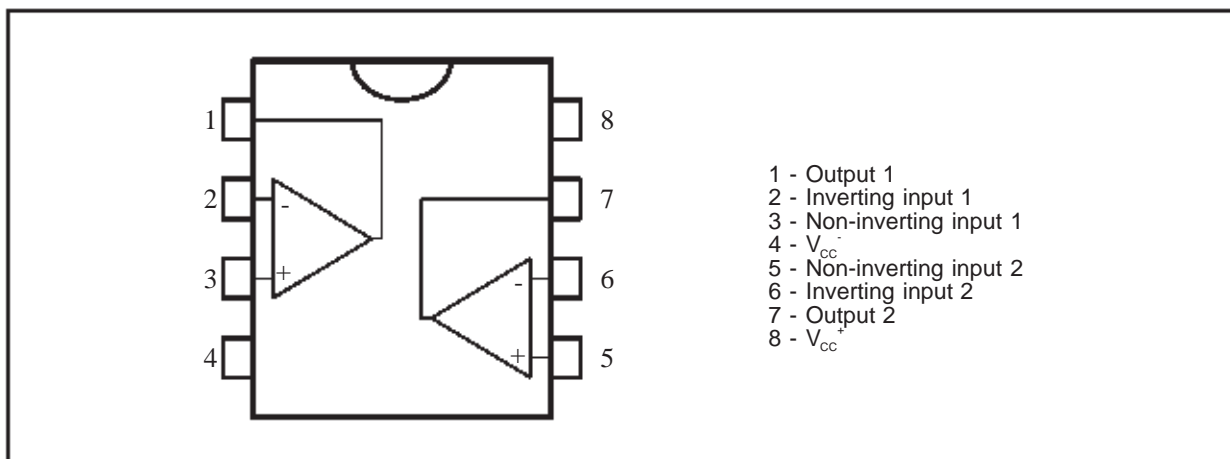

SCHMATIC DIAGRAM (1/2 LM2903)

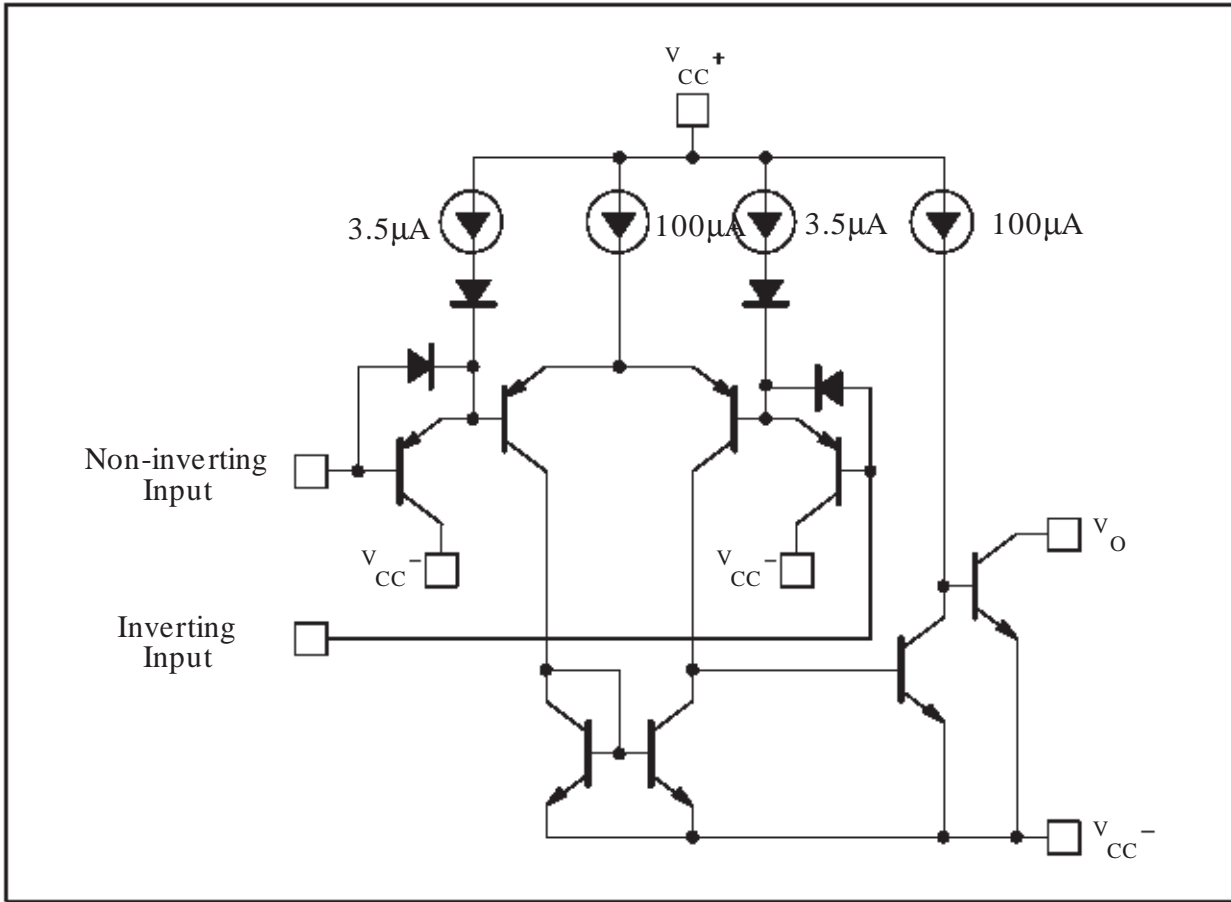

ABSOLUTE MAXIMUM RATINGS

Symbol	Parameter	Value	Unit
V _{CC}	Supply Voltage	±18 or 36	V
V _{id}	Differential Input Voltage	!36	V
V _i	Input Voltage	-0.3 to +36	V
	Output Short-circuit to Ground – (note 1)	Infinite	
P _{tot}	Power Dissipation	830	mW
T _{oper}	Operating Free-air Temperature Range	-40 to +125	°C
T _{stg}	Storage Temperature Range	-65 to +150	°C

Notes : 1. Short-circuit from the output to V_{CC}⁺ can cause excessive heating and eventual destruction. The maximum output current is approximately 20mA, independent of the magnitude of V_{CC}⁺.

ELECTRICAL CHARACTERISTICS
 $V_{CC}^+ = +5V$, $V_{CC}^- = 0V$, $T_{amb} = 25^\circ C$ (unless otherwise specified)

Symbol	Parameter	Min.	Typ.	Max.	Unit
V_{io}	Input Offset Voltage – (note 2) $T_{amb} = +25^\circ C$ $T_{min} \leq T_{amb} \leq T_{max}$		1	7 15	mV
I_{ib}	Input Bias Current – (note 3) $T_{amb} = +25^\circ C$ $T_{min} \leq T_{amb} \leq T_{max}$		25	250 400	nA
I_{io}	Input Offset Current $T_{amb} = +25^\circ C$ $T_{min} \leq T_{amb} \leq T_{max}$		5	50 150	nA
A_{vd}	Large Signal Voltage Gain $V_{CC} = 15V$, $R_L = 15k\Omega$, $V_o = 1$ to $11V$	25	200		V/mV
I_{CC}	Supply Current (all comparators) $V_{CC} = 5V$, no load $V_{CC} = 30V$, no load		0.4 1	1 2.5	mA
V_{icm}	Input Common Mode Voltage Range ($V_{CC} = 30V$) - (note 4) $T_{amb} = +25^\circ C$ $T_{min} \leq T_{amb} \leq T_{max}$	0 0		$V_{CC}^+ - 1.5$ $V_{CC}^+ - 2$	V
V_{id}	Differential Input Voltage - (note 6)			V_{CC}^+	V
I_{sink}	Output Sink Current ($V_{id} = -1V$, $V_o = 1.5V$)	6	16		mA
V_{OL}	Low Level Output Voltage ($V_{id} = -1V$, $I_{sink} = 4mA$) $T_{amb} = 25^\circ C$ $T_{min} \leq T_{amb} \leq T_{max}$		250	400 700	mV
I_{OH}	High Level Output Current ($V_{id} = 1V$, $V_{CC} = V_o = 30V$) $T_{amb} = 25^\circ C$ $T_{min} \leq T_{amb} \leq T_{max}$		0.1	1	nA μA
t_{re}	Small Signal Response Time ($R_L = 5.1k\Omega$ to V_{CC}^+) - (note 5)		1.3		μs
t_{rel}	Large Signal Response Time - (note 7) TTL Input ($V_{ref} = +1.4V$, $R_L = 5.1k\Omega$ to V_{CC}^+) Output Signal at 50% of final value Output Signal at 95% of final value			500 1	ns μs

- Notes :
- At output switch point, $V_o \neq 1.4V$, $R_s = 0\Omega$ with V_{CC}^+ from 5V to 30V and over the full input common-mode range (0V to $V_{CC}^+ - 1.5V$).
 - The direction of the input current is out of the IC due to the PNP input stage. This current is essentially constant, independent of the state of the output, so no loading charge exists on the reference or input lines.
 - The input common-mode voltage of either input signal voltage should not be allowed to go negative by more than 0.3V. The upper end of the common-mode voltage range is $V_{CC}^+ - 1.5V$, but either or both inputs can go to +30V without damage.
 - The response time specified is for a 100mV input step with 5mV overdrive.
 - Positive excursions of input voltage may exceed the power supply level.
As long as the other voltage remains within the common-mode range the comparator will provide a proper output state. The low input voltage state must not be less than $-0.3V$ (or $0.3V$ below the negative power supply, if used).
 - Maximum values are guaranteed by design.

SUPPLY CURRENT versus SUPPLY VOLTAGE

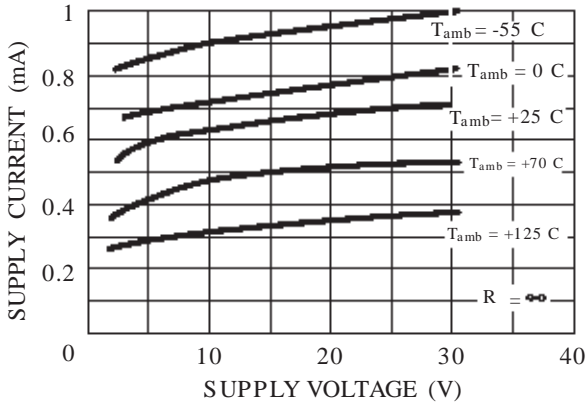

INPUT CURRENT versus SUPPLY VOLTAGE

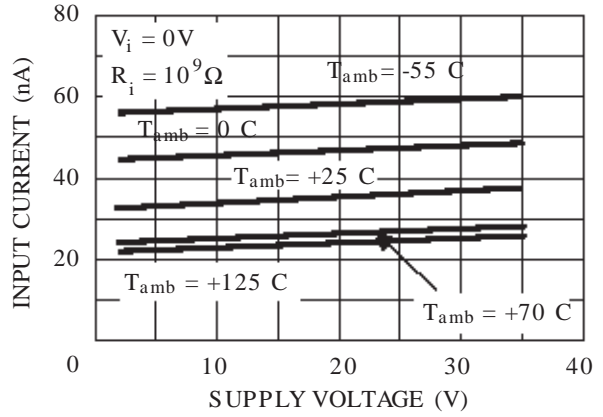

OUTPUT SATURATION VOLTAGE versus OUTPUT CURRENT

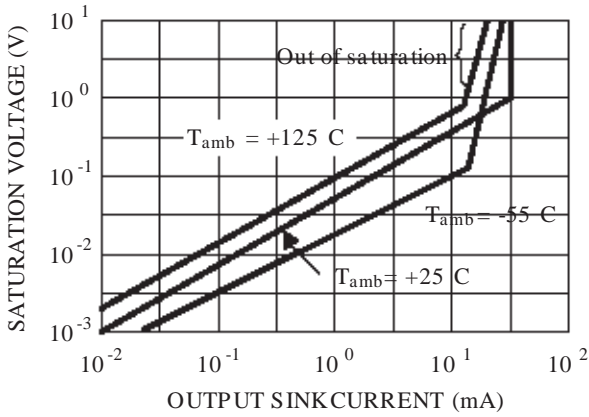

RESPONSE TIME FOR VARIOUS INPUT OVERDRIVES - NEGATIVE TRANSITION

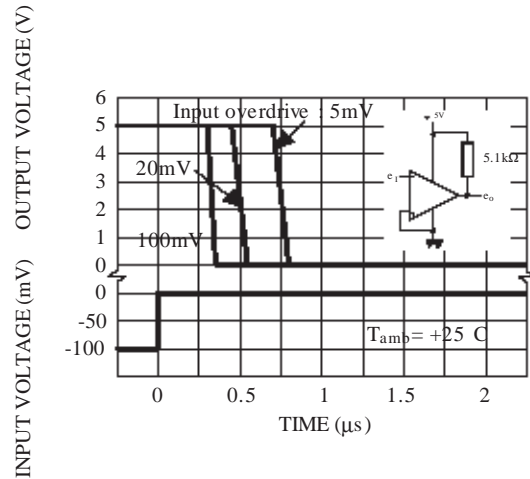

RESPONSE TIME FOR VARIOUS INPUT OVERDRIVES - POSITIVE TRANSITION

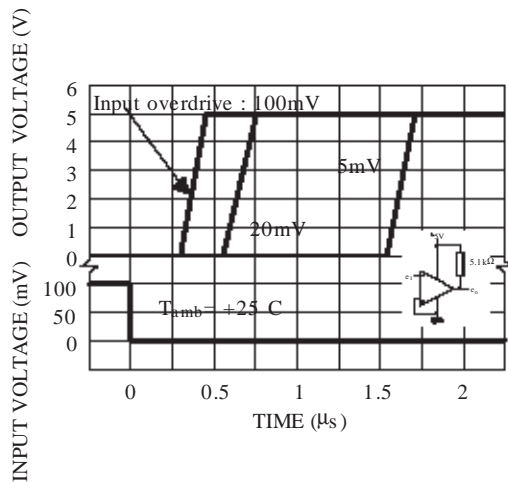

TYPICAL APPLICATIONS
BASIC COMPARATOR

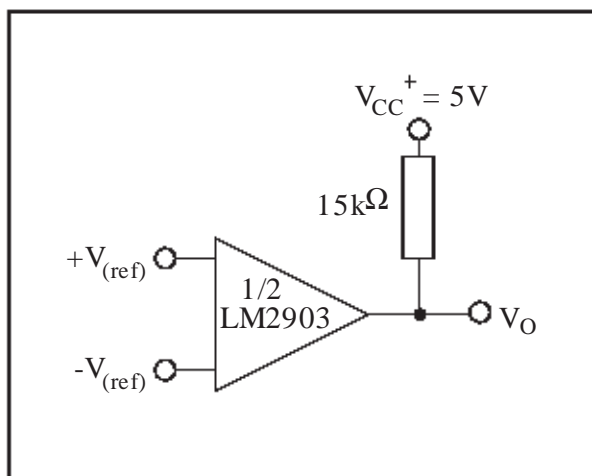

DRIVING CMOS

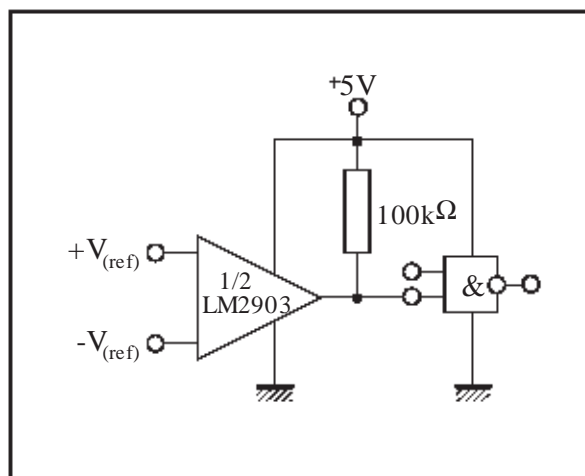

DRIVING TTL

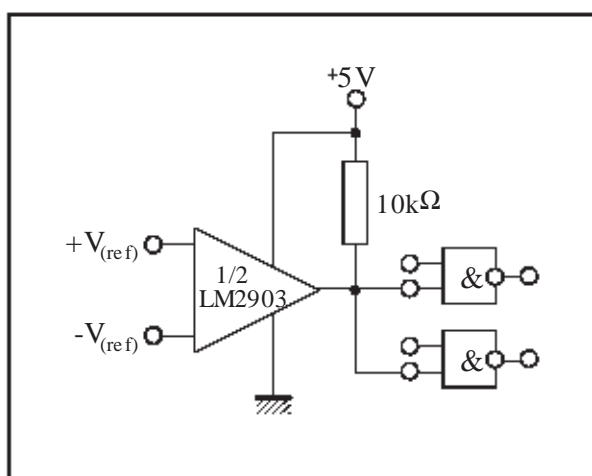

LOW FREQUENCY OP AMP

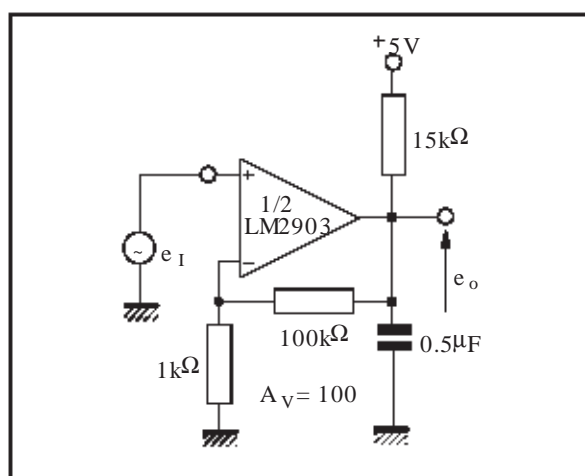

LOW FREQUENCY OP AMP

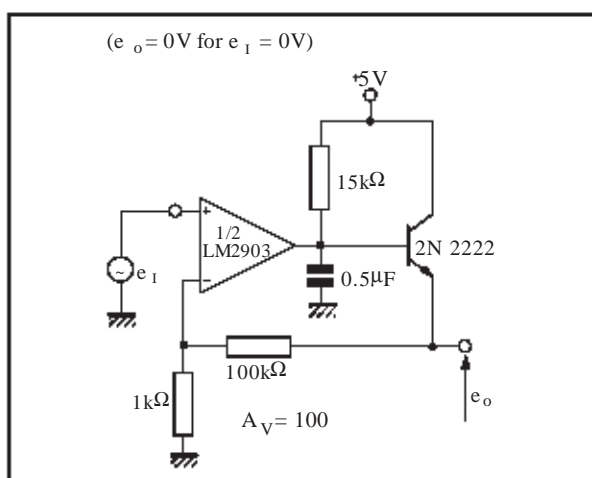

TRANSDUCER AMPLIFIER

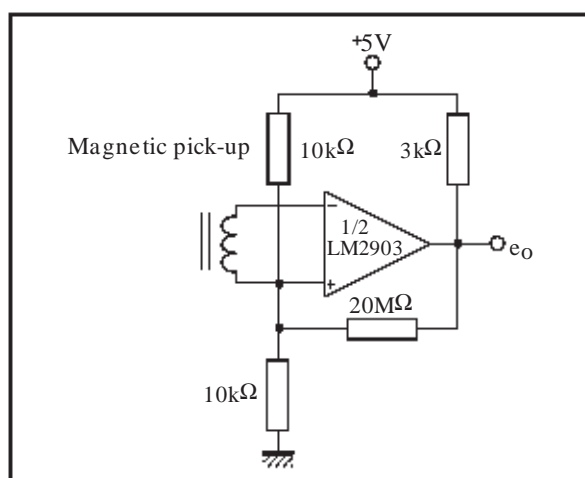

LM2903

LOW FREQUENCY OP AMP WITH OFFSET ADJUST

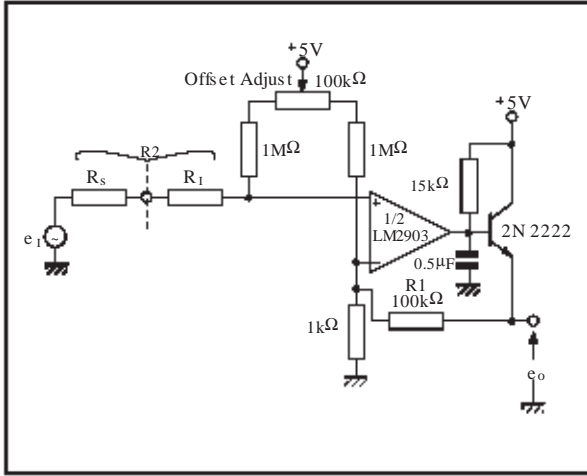

ZERO CROSSING DETECTOR (SINGLE POWER SUPPLY)

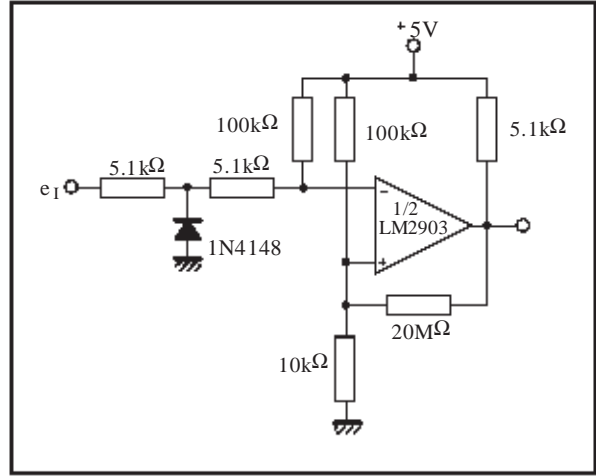

TWO DECADES HIGH FREQUENCY VCO

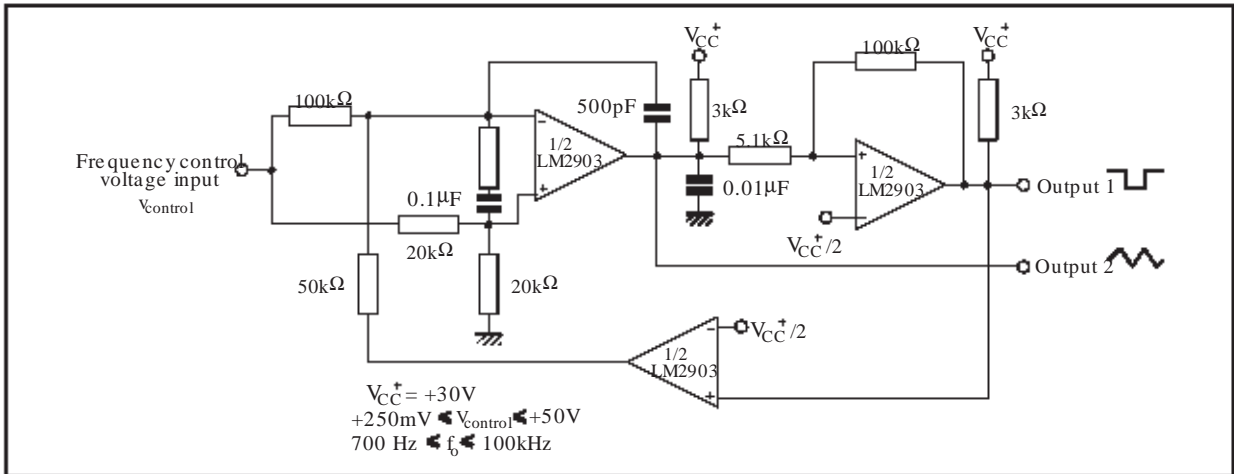

LIMIT COMPARATOR

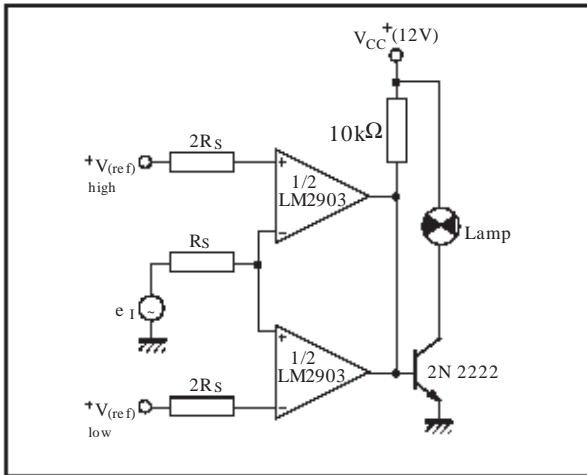

CRYSTAL CONTROLLED OSCILLATOR

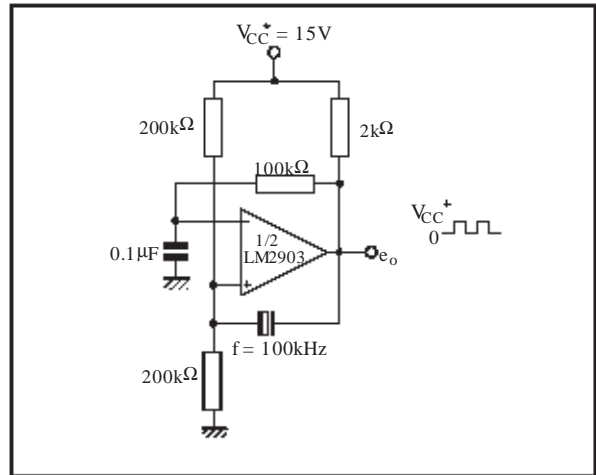

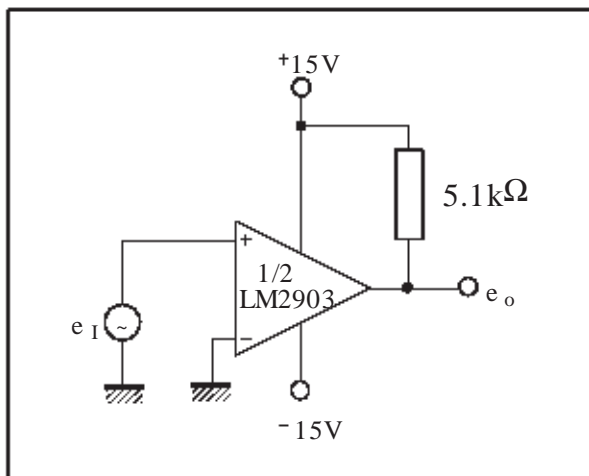
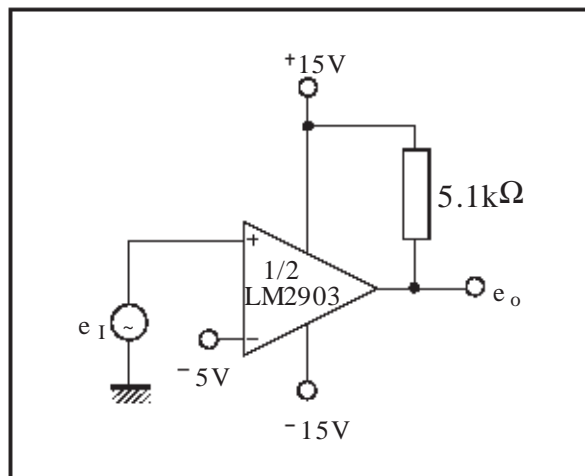
SPLIT-SUPPLY APPLICATIONS
ZERO CROSSING DETECTOR**COMPARATOR WITH A NEGATIVE REFERENCE**

LM2903

PACKAGE MECHANICAL DATA 8 PINS -PLASTIC DIP

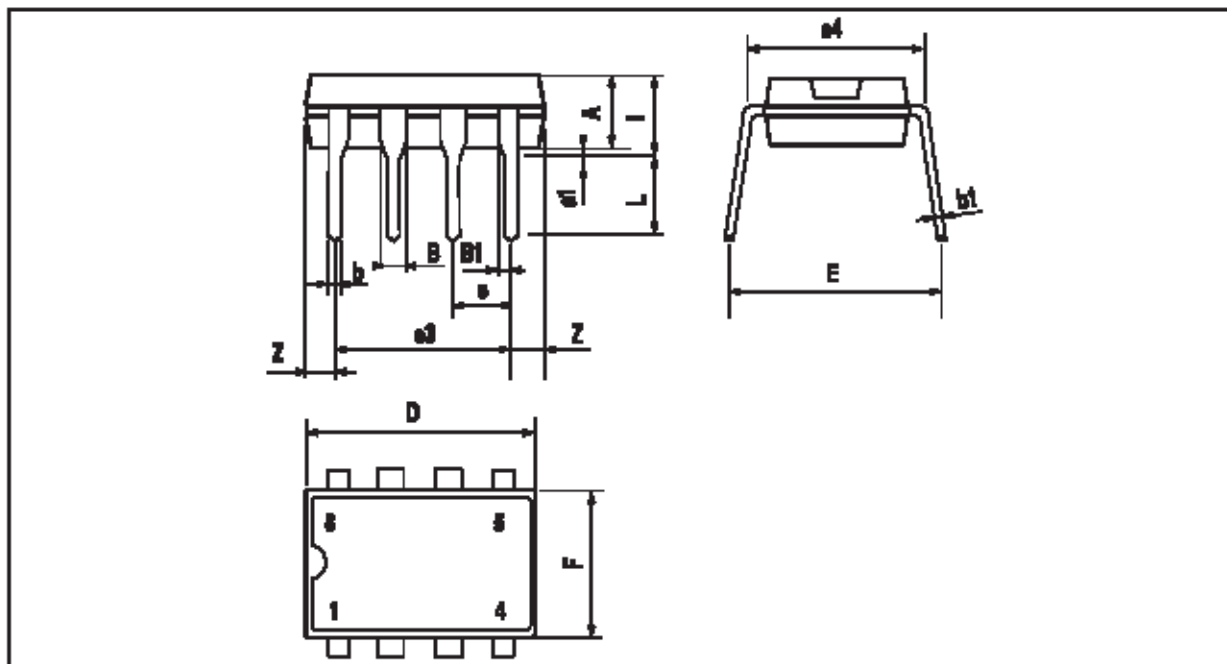

Dimensions	Millimeters			Inches		
	Min.	Typ.	Max.	Min.	Typ.	Max.
A		3.32			0.131	
a1	0.51			0.020		
B	1.15		1.65	0.045		0.065
b	0.356		0.55	0.014		0.022
b1	0.204		0.304	0.008		0.012
D			10.92			0.430
E	7.95		9.75	0.313		0.384
e		2.54			0.100	
e3		7.62			0.300	
e4		7.62			0.300	
F			6.6			0.260
i			5.08			0.200
L	3.18		3.81	0.125		0.150
Z			1.52			0.060

PACKAGE MECHANICAL DATA
8 PINS -PLASTIC MICROPACKAGE (SO)

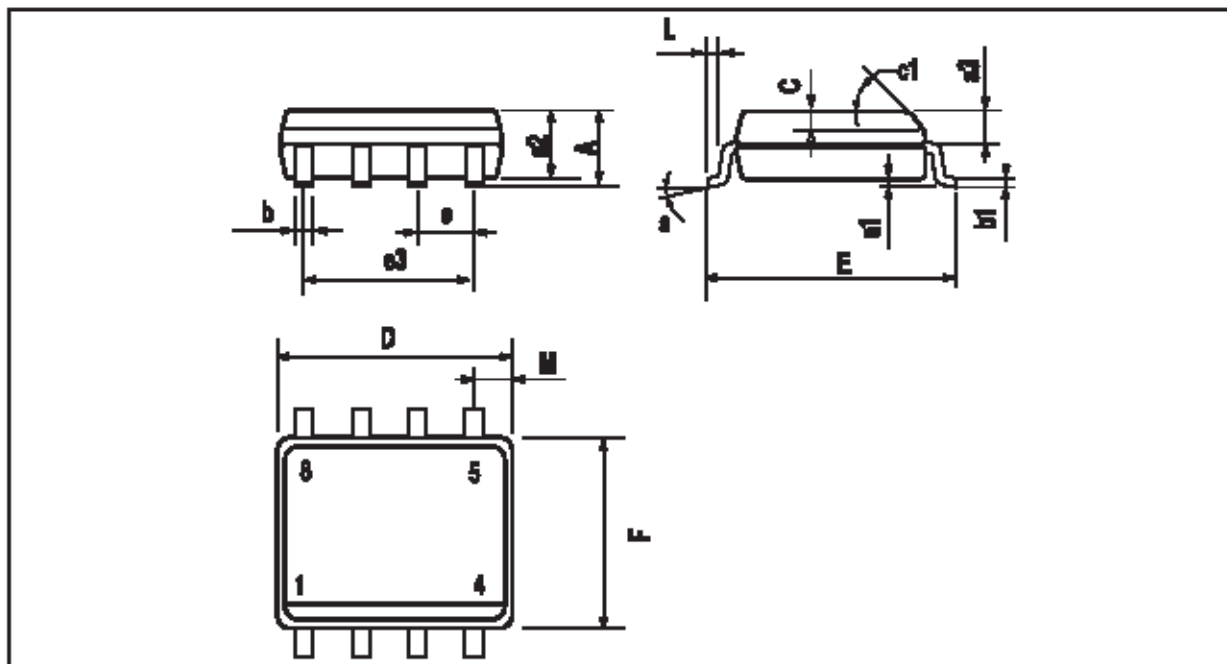

Dimensions	Millimeters			Inches		
	Min.	Typ.	Max.	Min.	Typ.	Max.
A			1.75			0.069
a1	0.1		0.25	0.004		0.010
a2			1.65			0.065
a3	0.65		0.85	0.026		0.033
b	0.35		0.48	0.014		0.019
b1	0.19		0.25	0.007		0.010
C	0.25		0.5	0.010		0.020
c1	45° (typ.)					
D	4.8		5.0	0.189		0.197
E	5.8		6.2	0.228		0.244
e		1.27			0.050	
e3		3.81			0.150	
F	3.8		4.0	0.150		0.157
L	0.4		1.27	0.016		0.050
M			0.6			0.024
S	8° (max.)					

PACKAGE MECHANICAL DATA
8 PINS -THIN SHRINK SMALL OUTLINE PACKAGE

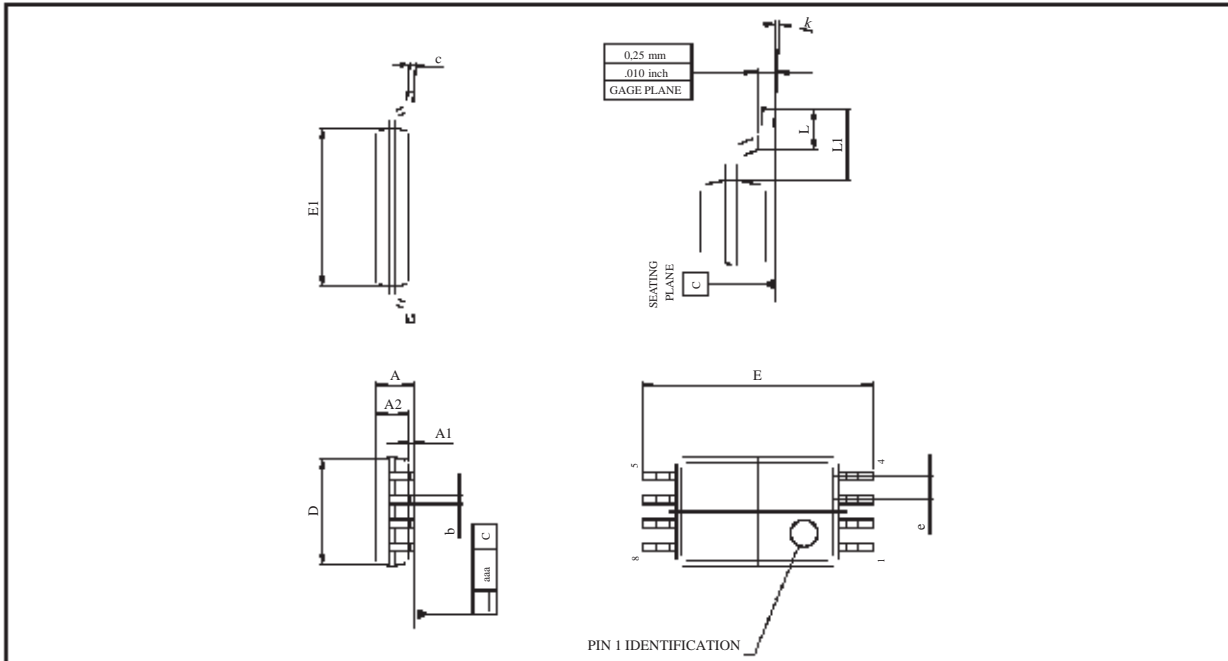

Dim.	Millimeters			Inches		
	Min.	Typ.	Max.	Min.	Typ.	Max.
A			1.20			0.05
A1	0.05		0.15	0.01		0.006
A2	0.80	1.00	1.05	0.031	0.039	0.041
b	0.19		0.30	0.007		0.15
c	0.09		0.20	0.003		0.012
D	2.90	3.00	3.10	0.114	0.118	0.122
E		6.40			0.252	
E1	4.30	4.40	4.50	0.169	0.173	0.177
e		0.65			0.025	
k	0°		8°	0°		8°
l	0.50	0.60	0.75	0.09	0.0236	0.030

Information furnished is believed to be accurate and reliable. However, STMicroelectronics assumes no responsibility for the consequences of use of such information nor for any infringement of patents or other rights of third parties which may result from its use. No license is granted by implication or otherwise under any patent or patent rights of STMicroelectronics. Specifications mentioned in this publication are subject to change without notice. This publication supersedes and replaces all information previously supplied. STMicroelectronics products are not authorized for use as critical components in life support devices or systems without express written approval of STMicroelectronics.

© The ST logo is a trademark of STMicroelectronics

© 2000 STMicroelectronics – Printed in Italy – All Rights Reserved
 STMicroelectronics GROUP OF COMPANIES

Australia - Brazil - China - Finland - France - Germany - Hong Kong - India - Italy - Japan - Malaysia - Malta - Morocco
 Singapore - Spain - Sweden - Switzerland - United Kingdom - U.S.A.

© <http://www.st.com>